

# M SERIES

## Wafer Address Sensor

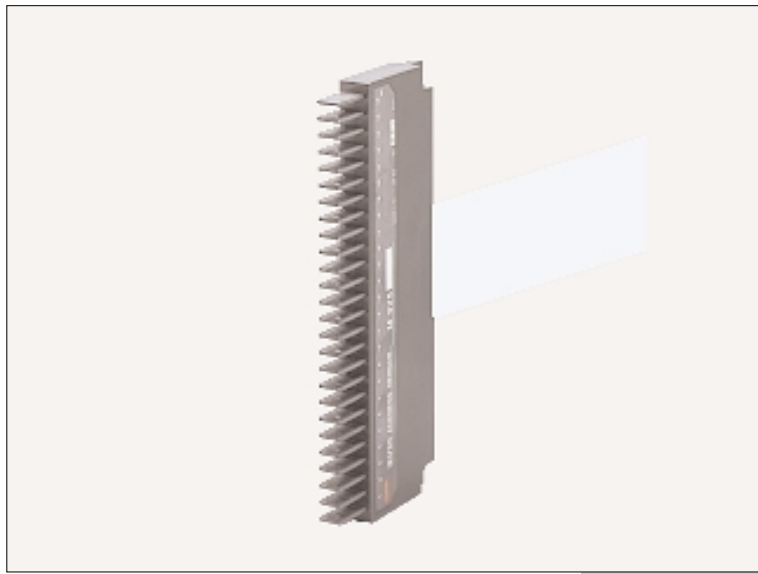

Simultaneous sensing of wafers in a cassette



### Compact size

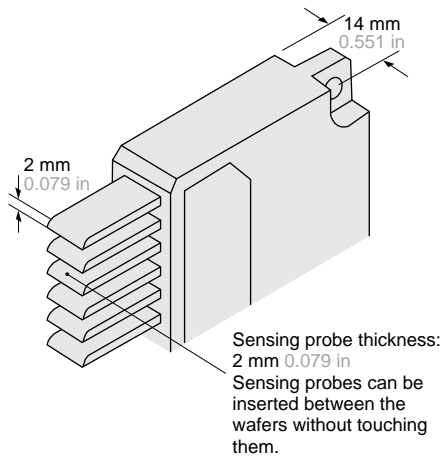

### Simultaneous sensing

All the wafers in the cassette can be sensed simultaneously. Three models are available that suit different size cassettes.

Item	Model No.	M-825	M-826	M-625
Wafer size		8 inches	8 inches	6 inches
Quantity		25 pieces	26 pieces	25 pieces

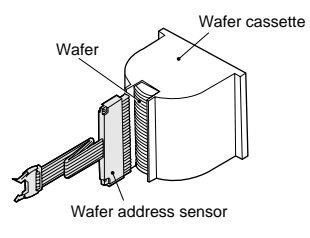

### Sensor check possible

If the output signal follows the ON / OFF of the test input (emission halt) signal, the sensor operation is normal.

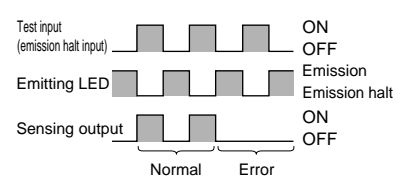

### PLC I/O port saving

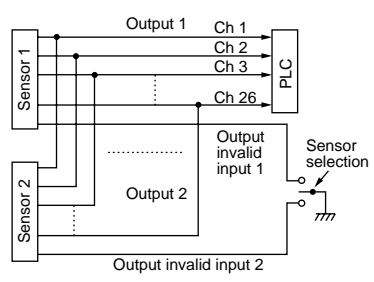

Even when several sensors are used, it is possible to feed their outputs to the same external input port by switching the output invalid inputs.



### Not affected by wafer color

Not affected by the wafer surface color since it is thru-beam type.

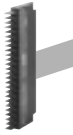
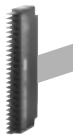
## ORDER GUIDE

Type	Appearance	Wafer pitch	Model No.
For 8 inch wafer		6.35 mm 0.250 in	<b>M-825</b>
			<b>M-826</b>
For 6 inch wafer		4.76 mm 0.187 in	<b>M-625</b>

## SPECIFICATIONS

Item	Type Model No.	For 8 inch wafer		For 6 inch wafer
		25 pieces <b>M-825</b>	26 pieces <b>M-826</b>	25 pieces <b>M-625</b>
Wafer pitch		6.35 mm 0.250 in		4.76 mm 0.187 in
Supply voltage		20 to 26.4 V DC Ripple P-P 10 % or less		
Current consumption		200 mA or less		
Sensing output		NPN open-collector transistor • Maximum sink current: 20 mA • Applied voltage: 30 V DC or less (between sensing output and 0 V) • Residual voltage: 1 V or less (at 20 mA sink current)		
	Utilization category	DC-12 or DC-13		
	Number of channels	25 channels	26 channels	25 channels
	Output operation	Dark-ON		
Response time		1 ms or less		
Test input (emission halt) function		Incorporated		
Output invalid (external synchronization) function		Incorporated		
Power indicator		Red LED (lights up when the power is ON)		
Environmental resistance	Pollution degree	3 (Industrial environment)		
	Ambient temperature	0 to +40 °C +32 to +104 °F (No dew condensation), Storage: -25 to +60 °C -13 to +140 °F		
	Ambient humidity	35 to 85 % RH, Storage: 35 to 85 % RH		
	Ambient illuminance	Fluorescent light: 1,500 lx at the light-receiving face, Incandescent light: 100 lx at the light-receiving face		
	EMC	EN 50081-2, EN 50082-2, EN 60947-5-2		
	Voltage withstandability	1,000 V AC for one min. between all supply terminals connected together and enclosure		
	Insulation resistance	20 MΩ, or more, with 500 V DC megger between all supply terminals connected together and enclosure		
	Vibration resistance	10 to 150 Hz frequency, 0.75 mm 0.030 in amplitude in X, Y and Z directions for two hours each		
	Shock resistance	490 m/s <sup>2</sup> acceleration (50 G approx.) in X, Y and Z directions for three times each		
Emitting element		Infrared LED (modulated)		
Material		Sensing probe: PPS, Enclosure: ABS, Connector: PBT		
Cable		1.27 mm 0.050 in pitch 30-core flexible flat cable, 500 mm 19.685 in long with clamp connector		
Cable extension		Extension up to total 20 m 65.617 ft is possible with an equivalent cable.		
Weight		150 g approx.		
Accessory		Spacer: 2 pcs.		

M-DW1

Glass Substrate / Wafer Sensing

FD-L43

SH-72

M

HD-T1

Liquid Leak / Liquid Level Sensing

EX-F70/F60

FD-F7

FT-F9

FX-301-F

# M

## I/O CIRCUIT AND PIN POSITION

### I/O circuit diagram

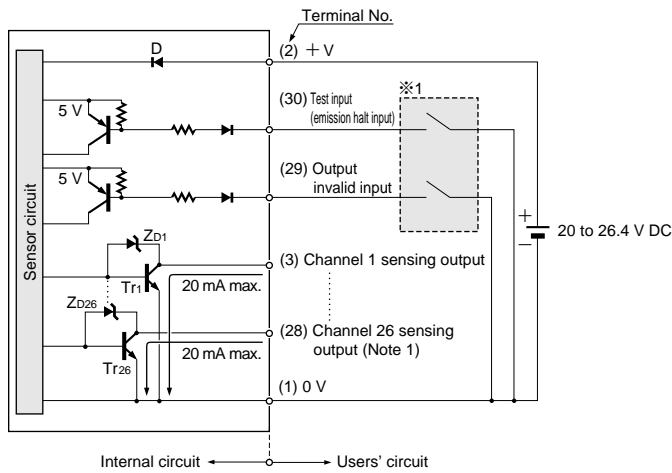

Notes: 1) Terminal No. 28 of **M-825** and **M-625** is assigned 0 V.  
 2) The sensing output does not incorporate a short-circuit protection circuit. Do not connect it directly to a supply or a capacitive load.

Symbols ... D: Reverse supply polarity protection diode  
 Z<sub>D1</sub> to Z<sub>D26</sub>: Surge absorption zener diode  
 Tr<sub>1</sub> to Tr<sub>26</sub>: NPN output transistor

※1

Non-voltage contact or NPN open-collector transistor

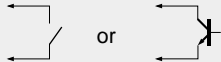

- Test input (emission halt input)  
 Low (1.5 V or less): Emission halt  
 High (3.6 V or more): Emission
- Output invalid input  
 Low (1.5 V or less): All channels OFF  
 High (3.6 V or more): Output possible

### Connector pin position

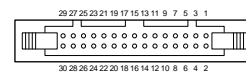
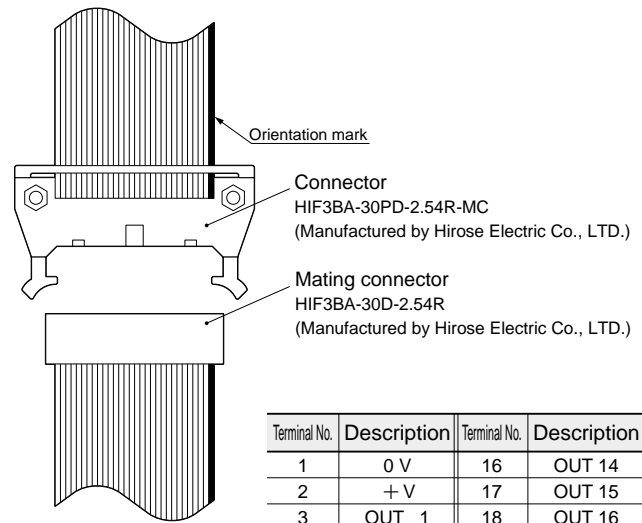

Terminal No.	Description	Terminal No.	Description
1	0 V	16	OUT 14
2	+ V	17	OUT 15
3	OUT 1	18	OUT 16
4	OUT 2	19	OUT 17
5	OUT 3	20	OUT 18
6	OUT 4	21	OUT 19
7	OUT 5	22	OUT 20
8	OUT 6	23	OUT 21
9	OUT 7	24	OUT 22
10	OUT 8	25	OUT 23
11	OUT 9	26	OUT 24
12	OUT 10	27	OUT 25
13	OUT 11	28	OUT 26 (Note)
14	OUT 12	29	Output invalid input
15	OUT 13	30	Test input (emission halt input)

Note: Terminal No.28 of **M-825** and **M-625** is assigned 0 V.

## PRECAUTIONS FOR PROPER USE

Refer to p.1135~ for general precautions.



This product is not a safety sensor. Its use is not intended or designed to protect life and prevent body injury or property damage from dangerous parts of machinery. It is a normal object detection sensor.

- Adjust the mounting of the sensor so that when the wafers are inserted into the spaces between the sensor probes, the distance between the orientation flats and the sensor body is 12 mm 0.472 in or less.

### Mounting

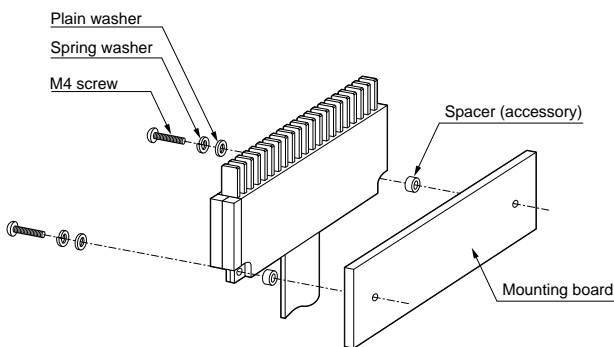

- Attached spacers must be used to mount the sensor.
- The tightening torque of the M4 screws should be 0.78 N·m or less.
- Carefully mount the sensor so that the sensing probes do not touch any wafer.

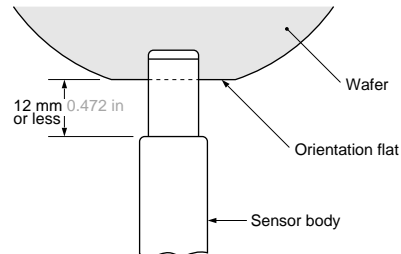

### Wiring

- The sensing output does not incorporate a short-circuit protection circuit. Do not connect it directly to a power supply or a capacitive load.

### Others

- Do not use during the initial transient time (100 ms) after the power supply is switched on.

**PRECAUTIONS FOR PROPER USE**

Refer to p.1135~ for general precautions.

**Test input (emission halt) function**

- When the test input (emission halt input) is turned ON (+ 1.5 V or less), all LEDs stop emission, generating the wafer sensed condition, and output transistors of all channels become ON.
- The output circuit of the sensor can be checked by using the test input (emission halt input).

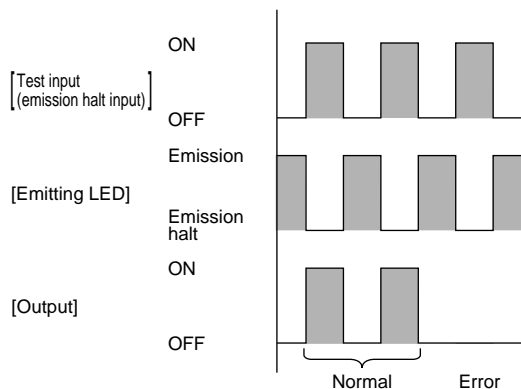

**Output invalid (external synchronization) function**

- If the output invalid input is turned ON (+ 1.5 V or less), the output transistors of all channels stay in the OFF state irrespective of the wafer detection condition.
- Several sensors can be used in parallel by using the output invalid inputs, thereby reducing the required PLC input points.

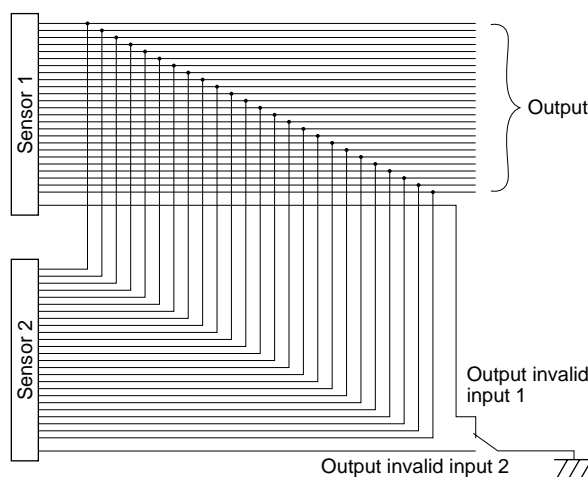

Switch position	Sensor operation
	Only Sensor 2 is operative
	Only Sensor 1 is operative

**DIMENSIONS (Unit: mm in)**

The CAD data in the dimensions can be downloaded from the SUNX website: <http://www.sunx.co.jp/>

**M-625  
M-825**

For 25 pieces of wafers

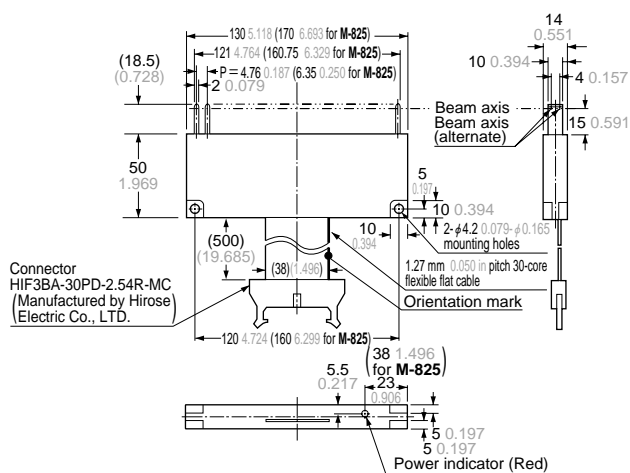

Mating connector: HIF3BA-30D-2.54R  
(Manufactured by Hirose Electric Co., LTD.)

**M-826**

For 26 pieces of wafers

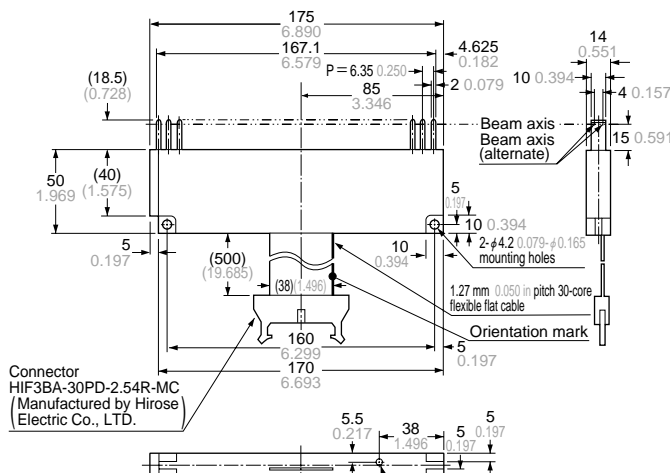

Mating connector: HIF3BA-30D-2.54R  
(Manufactured by Hirose Electric Co., LTD.)

SENISORS FOR SEMICONDUCTOR INDUSTRY  
 M-DW1  
 FD-L43  
 SH-72  
 M  
 HD-T1  
 EX-F70/F60  
 FD-F7  
 FT-F9  
 FX-301-F